

Varimixer

ERGO 100

ERGONOMIC HANDLING Separate removal of bowl and tools. The taller frame allows you to lower the bowl below the tool, so each of them can be removed separately, increasing efficiency.

STAINLESS STEEL CONTROL PANEL Choose between variable speed control, fixed speeds or up to 20 programs with your own programs. All operations are controlled from the intuitive control panel with responsive piezo push button technology. The panel is easy to clean and is dustproof and waterproof.

REMOVABLE The removable safety guard is made of stainless steel is easy to remove and dishwasher safe.

ERGONOMIC WORKING HEIGHT All work at Varimixer ERGO is done with a straight back. There is unhindered access to changing tools at the correct ergonomic working height.

ONE MACHINE – MULTIPLE CAPACITIES The ERGO100 has optional equipment for 60 and 40-litre production. The option of producing reduced quantities makes the large machines more versatile.

AUTOMATIC BOWL LOWERING It is not necessary to watch the mixing process. When the time is up, the control system lowers the bowl, so the tools can drip off directly into the bowl.

LIFT FOR EASY HANDLING Even the largest bowls can be easily and ergonomically lifted using an electronic bowl lift, which also ensures correct working height during filling and emptying. Choose from several models - or choose a manual bowl truck for transport only.

HYGIENIC AND EASY TO CLEAN ERGO 100 is available in white or stainless steel. All accessories are made of stainless steel, and the design ensures the best possible hygiene and very easy cleaning. Varimixer ERGO can be washed in accordance with the IP53 standard, and can be upgraded to either a marine version or IP54 cleaning, with a waterproof stainless steel mixer head.

NO HEAVY LIFTING The bowl is wheeled into place between the two arms. The bowl is automatically centered and locked into position, when raised.



VARIMIXER ERGO 100 OPTIONS – MODELS



White, powder coated



Stainless steel



Marine version

OPTIONS – IP54



Waterproof planetary head, stainless steel, IP54



Double chimney, stainless steel, IP54

OPTIONS – SAFETY GUARDS

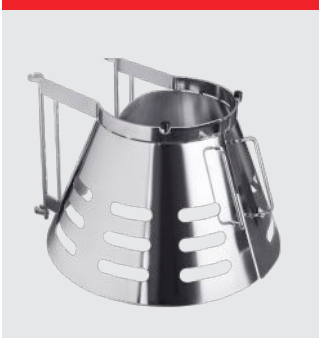

Removable safety guard in stainless steel. CE-certified

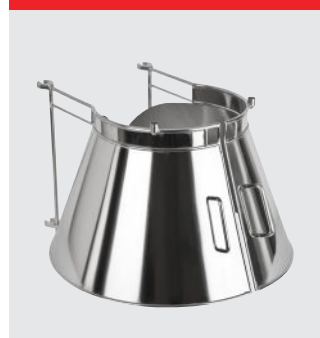

Removable splash guard in stainless steel. CE-certified

VARIMIXER ERGO 100 STANDARD TOOLS – A-EQUIPMENT 100L



Whip with double pin, hook with double pin, beater with double pin and bowl 100 liter in stainless steel.

VARIMIXER ERGO 100 STANDARD TOOLS – B-EQUIPMENT 100/60L AND C-EQUIPMENT 100/40L



Whip, hook, beater and bowl 100/60 liter in stainless steel and Whip, hook, beater and bowl 100/40 liter in stainless steel.

OPTION - TOOLS



Wing whip with double pin, stainless steel



Whip with double pin, with thinner wires, stainless steel



Whip with double pin, with reinforcement



Powder mixer with double pin, stainless steel



Beater with double pin, aluminium



Automatic scraper, stainless steel. 100L 100/60L and 100/40L.



Tool rack, 127 cm

EQUIPMENT - TRANSPORTION



Bowl truck



Easylift 80-140



Maxilift Inox



Bowl with bottom draining pipe, stainless steel



Wheels for bowl

VARIMIXER ERGO 100 STANDARD

White powder coated
1 bowl 100 liter in stainless steel
1 beater in aluminium with double pin
1 hook in stainless steel with double pin
1 whip with stainless steel wires with double pin
Removable safety guard in stainless steel – CE-certified
Separate removal of bowl and tool
Digital timer and emergency stop
Voltage: 3 ph, 400V, 50 Hz with ground. 4.000 W

VARIMIXER ERGO 100 STANDARD TECHNICAL DATA

Volume	100 l
Effect	4.000 W
Standard voltage*	400 V
Residual current devices (RCD):	
Industrial environment	HPFI type A-SI or PFI type B
Light industry/domestic	HPFI type A-SI
Net weight	428 kg
H x W x L	2035 x 761 x 1207 mm
Variable speed	47 – 257 RPM
Phases	3 ph
IP code	IP53
IP code upgrade package	IP54

*Other voltage power supply are available upon request in the range of 100 to 480 V.
All standard and marine mixers are available in 50 and 60 Hz.

VARIMIXER ERGO 100 MARINE VERSION

Stainless steel execution, water cover at air ventilation, slotted free screws, full welded stainless steel knees, gasket at the rear plate, gasket at front panel and top cover. Complies with USPHS.

Voltage: 3 ph, 440V, 50 Hz with ground. 4.000 W
3 ph, 480V, 50 Hz with ground. 4.000 W

DIMENSIONS

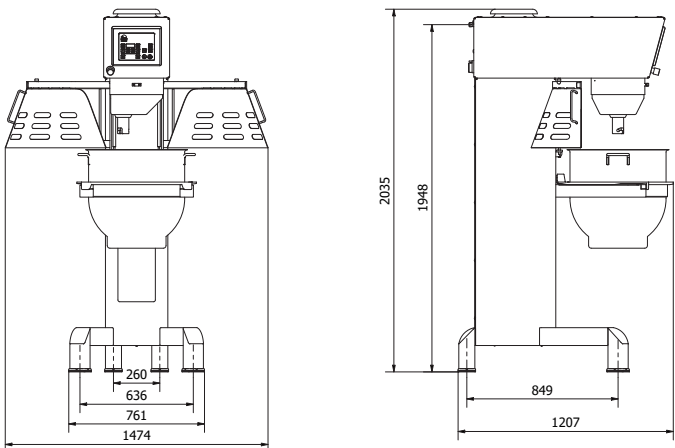

CERTIFICATIONS



Varimixer

Varimixer A/S
Kirkebjerg Søpark 6
DK-2605 Brøndby
P: +45 4344 2288
E: info@varimixer.com
www.varimixer.com