



# REFRIGERATED DISPLAY



**HAGLUND INDUSTRI**  
KYLA | ALLA FORMER

## TECHNOLOGY, FUNCTION AND DURABILITY

For five generations, the Haglund family has been manufacturing products in our factory in Rånnaväg. From our early days in sheet metal craftsmanship to today's high-quality refrigerators, our guiding principles have remained the same: listen to our customers, pay close attention to every detail, and continuously advance technology and functionality. This tradition is embedded in every product we create, ensuring a level of quality and durability that sets us apart. Each product undergoes rigorous testing, first by us and then by our customers.

# 160 YEARS OF INNOVATION CAN BE SEEN IN THE DETAILS



## TABLE OF CONTENTS

- 3 REFRIGERATED DISPLAYS
- 7 SMAKA REFRIGERATED DISPLAY
- 6 ACCESSORIES SMAKA
- 7 SMAKA-MX
- 9 REFRIGERATED DISPLAY / PASTRY DISPLAY
- 10 REFRIGERATED COUNTER & SELF-SERVE DISPLAY
- 11 DELI COUNTERS
- 13 DELIKAT DELI COUNTERS

### FEEL FREE TO CONTACT US FOR AN ESTIMATE

Every restaurant and catering establishment has unique needs. Contact us with your requirements, and we'll provide a tailored proposal.

EMAIL US AT: [SALES@HAGLUNDINDUSTRI.SE](mailto:SALES@HAGLUNDINDUSTRI.SE)  
OR CALL: +46 (0) 321-29 990

# SMAKA REFRIGERATED DISPLAY

## SELF-SERVICE AND COMMERCIAL DISPLAY

SMAKA is a line of displays created to enhance modern spaces while showcasing your products attractively for customers. With features such as low energy consumption, a stylish design, and easy maintenance, SMAKA has been a top choice for many cafés from the start. Customers appreciate its flexibility and the option to create customised versions tailored to their specific needs.



### STAY STYLISH

Designed with a sleek, exclusive aesthetic, it seamlessly integrates into a wide range of environments and maintains its stylish appeal for years to come.

### WIDE RANGE

We offer a diverse range of stands in standard designs, with the flexibility to easily customise them to meet your specific requirements.

### EVEN COOLING

Our innovative air distribution system ensures even cooling across all shelves, extending product shelf life and optimising energy efficiency.

### DURABLE STAINLESS STEEL FRAME

Includes front, end panels, top, and sliding doors with insulated glass

SMAKA REFRIGERATED DISPLAY



### TWO TEMPERATURE ZONES (OPTIONAL)

Includes a partition to create distinct temperature zones and separate storage spaces.

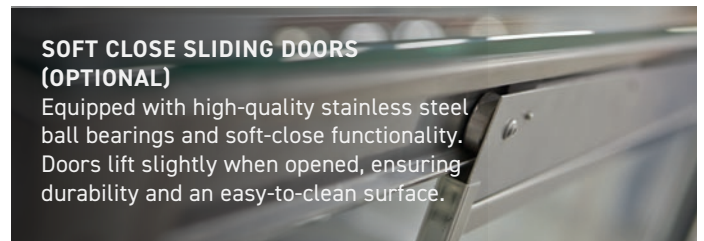

### SOFT CLOSE SLIDING DOORS (OPTIONAL)

Equipped with high-quality stainless steel ball bearings and soft-close functionality. Doors lift slightly when opened, ensuring durability and an easy-to-clean surface.



UV BONDED  
GLASS DISPLAY  
CASE WITHOUT  
FRAME

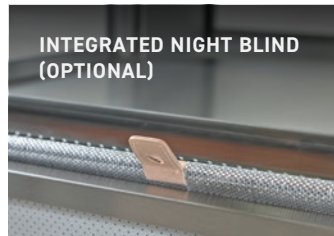

INTEGRATED NIGHT BLIND  
(OPTIONAL)



LED LIGHTING ON ALL  
SHELVES



### AIR PILLAR TECHNOLOGY

Our air distribution system ensures even cooling, reducing product dehydration while maximising shelf space and display area.

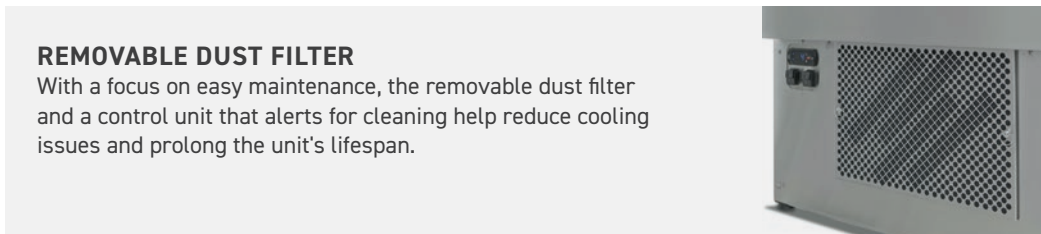

### REMOVABLE DUST FILTER

With a focus on easy maintenance, the removable dust filter and a control unit that alerts for cleaning help reduce cooling issues and prolong the unit's lifespan.



SMÅKA REFRIGERATED DISPLAY

# REFRIGERATED DISPLAYS

## EXPOSURE

A Perfect display for sandwiches, pastries, salads, sauces, and more in your serving line. Conveniently refillable from the inside.

## EFFICIENT COOLING SYSTEM

Our products are rigorously tested under demanding conditions and utilise proprietary compressor cooling technology for improved efficiency and long-lasting performance.

## EVEN TEMPERATURE THROUGHOUT THE WHOLE STAND

Our innovative air distribution system ensures uniform cooling across the entire stand.

## FLEXIBLE

We offer the option to create stands and displays in different dimensions to suit your specific needs.

REFRIGERATED DISPLAYS

# SMAKA

**CLOSED REFRIGERATED DISPLAYS**

MODEL	SMAKA-06SA	SMAKA-08SA	SMAKA-10SA	SMAKA-12SA
DIMENSION (mm)	600 x 700 x 1300	800 x 700 x 1300	1000 x 700 x 1300	1200 x 700 x 1300
SHELVES	3	3	3	3

MODEL	SMAKA-14SA	SMAKA-16SA	SMAKA-20SA
DIMENSION (mm)	1400 x 700 x 1300	1600 x 700 x 1300	2000 x 700 x 1300
SHELVES	3	3	3

**ACCESSORIES**

- GLASS DISPLAY
- SNEEZE GUARD
- TILT OUT GLASSFRONT



**SMAKA 08HA**

Image: Equipped with optional night blind.

**REFRIGERATED DISPLAYS WITH TWO SEPARATED TEMPERATURE ZONES**

MODEL	SMAKA-D16SA-01	SMAKA-D16SA-02	SMAKA-D20SA-01	SMAKA-D20SA-02
DIMENSION (mm)	1600 x 700 x 1300	1600 x 700 x 1300	2000 x 700 x 1300	2000 x 700 x 1300
LEFT ZONE	600 mm	800 mm	600 mm	800 mm
RIGHT ZONE	1 000 mm	800 mm	1 400 mm	1 200 mm

MODEL	SMAKA-D20SA-03	SMAKA-D24SA-01	SMAKA-D24SA-02	SMAKA-D24SA-03
DIMENSION (mm)	2000 x 700 x 1300	2400 x 700 x 1300	2400 x 700 x 1300	2400 x 700 x 1300
LEFT ZONE	1 000 mm	800 mm	1 000 mm	1 200 mm
RIGHT ZONE	1 000 mm	1 600 mm	1 400 mm	1 200 mm

**ACCESSORIES**

- GLASS DISPLAY
- SNEEZE GUARD
- TILT OUT GLASSFRONT

**OPEN REFRIGERATED DISPLAYS (INTENDED FOR BEVERAGES)**

MODEL	SMAKA-08A	SMAKA-10A	SMAKA-08HA	SMAKA-10HA
DIMENSION (mm)	800 x 700 x 1300	1000 x 700 x 1300	800 x 700 x 1500	1000 x 700 x 1500
SHELVES	2	2	3	3

**ACCESSORIES**

- GLASS DISPLAY
- SNEEZE GUARD

**NEUTRAL DISPLAY**

MODEL	SMAKA-08SN	SMAKA-10SN	SMAKA-12SN	SMAKA-14SN
SHELF (mm)	685 x 560	885 x 560	1085 x 560	1285 x 560
DIMENSION (mm)	800 x 700 x 1300	1000 x 700 x 1300	1200 x 700 x 1300	1400 x 700 x 1300

MODEL	SMAKA-16SN	SMAKA-18SN	SMAKA-20SN
SHELF (mm)	1485 x 560	2 x (805 x 560)	2 x (805 x 560)
DIMENSION (mm)	1600 x 700 x 1300	1800 x 700 x 1300	2000 x 700 x 1300

**STANDARD**

- STAINLESS STEEL FRAME
- UNIQUE AIR DISTRIBUTION TECHNOLOGY FOR UNIFORM TEMPERATURE IN THE STAND
- LED LIGHTING ON EACH SHELF
- CLOSED TO CUSTOMER, SLIDING DOORS ON STAFF SIDE
- INSULATED GLASS



**SMAKA 16SA**

Image: Equipped with sneeze guard and 2 shelves instead of 3.

# ACCESSORIES SMAKA

## ACCESSORIES

SOFT CLOSE HANGING SLIDING GLASS WITH STAINLESS STEEL	LED 2700K
BALL BEARINGS MIN. WIDTH 800 MM	REMOTE COOLING UNIT
LOCK	BRINE
INCLINED GLASS FRONT	WATER-COOLED UNIT
INCLINED SHELVES	CO2 REFRIGERANT
OTHER DEPTH	NIGHT BLIND (OPEN STANDS)
OTHER HEIGHT	SLIDING DOORS AT THE FRONT (800-2000)
2 SHELVES INSTEAD OF 3	INTERIOR MIRROR
	RECESS FRONT, CUSTOM MEASUREMENTS
	ELECTRONIC HYGROSTAT

\*min. width 800 mm



## REMOTE COOLING UNIT

MODEL	SMAKA-06SC	SMAKA-08SC	SMAKA-10SC	SMAKA-12SC	SMAKA-14SC
POWER SUPPLY	230 V/10 A	230 V/10 A	230 V/10 A	230 V/10 A	230 V/10 A
CONNECTED POWER	200 W	200 W	200 W	200 W	200 W
COOLING REQUIREMENT	400 W/-10°C	500 W/-10°C	550 W/-10°C	600 W/-10°C	700 W/-10°C
REFRIGERANT	*	*	*	*	*

MODEL	SMAKA-16SC	SMAKA-20SC	SMAKA-24SC	SMAKA-08C	SMAKA-10C
POWER SUPPLY	230 V/10 A	230 V/10 A	230 V/10 A	230 V/10 A	230 V/10 A
CONNECTED POWER	200 W	250 W	250 W	200 W	200 W
COOLING REQUIREMENT	800 W/-10°C	1000 W/-10°C	1200 W/-10°C	800 W/-10°C	1000 W/-10°C
REFRIGERANT	*	*	*	*	*

MODEL	SMAKA-08HC	SMAKA-10HC
POWER SUPPLY	230 V/10 A	230 V/10 A
CONNECTED POWER	200 W	200 W
COOLING REQUIREMENT	1100 W/-10°C	1300 W/-10°C
REFRIGERANT	*	*

\*Upon request

## BUILT-IN UNIT

MODEL	SMAKA-06SA	SMAKA-08SA	SMAKA-10SA	SMAKA-12SA	SMAKA-14SA
POWER SUPPLY	230 V/10 A	230 V/10 A	230 V/10 A	230 V/10 A	230 V/10 A
CONNECTED POWER	500 W	500 W	600 W	600 W	800 W
REFRIGERANT	R-290	R-290	R-290	R-290	R-290

MODEL	SMAKA-16SA	SMAKA-20SA	SMAKA-08A	SMAKA-10A	SMAKA-08HA
POWER SUPPLY	230 V/10 A	230 V/10 A	230 V/10 A	230 V/10 A	230 V/10 A
CONNECTED POWER	800 W	950 W	800 W	800 W	800 W
REFRIGERANT	R-290	R-290	R-290	R-290	R-290

MODEL	SMAKA-10HA	SMAKA-D16SA-01	SMAKA-D16SA-02	SMAKA-D20SA-01	SMAKA-D20SA-02
POWER SUPPLY	230 V/10 A	230 V/10 A	230 V/10 A	230 V/10 A	230 V/10 A
CONNECTED POWER	800 W	950 W	800 W	950 W	950 W
REFRIGERANT	R-290	R-290	R-290	R-290	R-290

MODEL	SMAKA-D20SA-03	SMAKA-D24SA-01	SMAKA-D24SA-02	SMAKA-D24SA-03
POWER SUPPLY	230 V/10 A	230 V/10 A	230 V/10 A	230 V/10 A
CONNECTED POWER	950 W	1200 W	1200 W	1200 W
REFRIGERANT	R-290	R-290	R-290	R-290

DISPLAYS INTEGRATED WITH REFRIGERATED COUNTER

# SMAKA MX

THE BEST OF BOTH WORLDS

## A SMAKA DISPLAY INTEGRATED WITH A MX REFRIGERATED COUNTER.

The Smaka MX display offers the best of both worlds: SMAKA's stylish display combined with MX's practical refrigerated storage, all in one smartly packaged product.

SMAKA-MX MONTER INTEGRERAD WITH REFRIGERATED COUNTER



**INTEGRATED LED LIGHTING ON EACH SHELF**

### OWN DEVELOPED COOLING SYSTEM

Independent controls for the refrigerated counter and display offer electronic temperature regulation with a digital readout, allowing for flexible configuration of settings for both.

### EFFECTIVE FILLING

With cold storage easily accessible, restocking products in the display case is quick and hassle-free.

### EVEN COOLING

Our air distribution system provides consistent cold air circulation throughout all shelves. Additionally, the counter includes a fan cooler that maintains even temperatures within the refrigeration space, prolonging product shelf life and enhancing energy efficiency.

# SMAKA MX

## EFFECTIVE FILLING

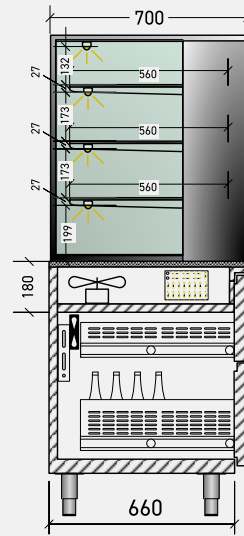
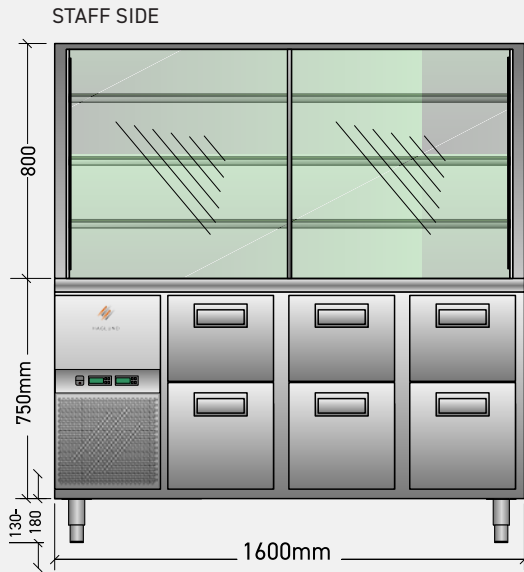

### STANDARD

- FRAME MADE ENTIRELY IN STAINLESS STEEL
- UNIQUE AIR DISTRIBUTION TECHNOLOGY FOR AN EVEN TEMPERATURE IN THE DISPLAY
- LED LIGHTING ON ALL SHELVES
- CLOSED TOWARDS THE CUSTOMER
- SLIDING DOORS ON THE STAFF SIDE
- INSULATED GLASS
- REFRIGERATED UNDERCOUNTER THAT CAN BE EQUIPPED WITH DOORS OR DRAWERS

### DIMENSIONS (mm)

WIDTH	800 /1200/1600/2000
DEPTH	700
HEIGHT	1700

### BUILT-IN UNIT

MODEL	SMAKA-MX-08SA	SMAKA-MX-12SA	SMAKA-MX-16SA	SMAKA-MX-20SA
DIMENSION (mm)	800 x 700 x 1700	1200 x 700 x 1700	1600 x 700 x 1700	2000 x 700 x 1700
POWER SUPPLY	230 V/10 A	230 V/10 A	230 V/10 A	230 V/10 A
CONNECTED POWER	500 W	700 W	900 W	1100 W
REFRIGERANT	R-290	R-290	R-290	R-290

### REMOTE COOLING UNIT

MODEL	SMAKA-MX-08SC	SMAKA-MX-12SC	SMAKA-MX-16SC	SMAKA-MX-20SC
DIMENSION (mm)	800 x 700 x 1700	1200 x 700 x 1700	1600 x 700 x 1700	2000 x 700 x 1700
POWER SUPPLY	230 V/10 A	230 V/10 A	230 V/10 A	230 V/10 A
CONNECTED POWER	200 W	200 W	250 W	250 W
COOLING REQUIREMENT	600 W/ -10°C	850 W/ -10°C	1050 W/ -10°C	1300 W/ -10°C
REFRIGERANT	R-134/R-452*	R-134/R-452*	R-134/R-452*	R-134/R-452*

### ACCESSORIES

- TILT OUT GLASSFRONT
- SNEEZE GUARD
- UV BONDED GLASS DISPLAY CASE WITHOUT FRAME
- LOCK
- BAR DRAWERS
- DOORS BAKERY TRAY

\*CO2 or other refrigerant can be supplied upon request.



## DISPLAY / COUNTERS

# REFRIGERATED COUNTER & SELF-SERVE DISPLAY



### ADAPTIVE

ALL MODELS ARE AVAILABLE IN EITHER A STRAIGHT OR ROUNDED CONFIGURATION.



### CONTROL

EQUIPPED WITH THREE INDEPENDENT COOLING UNITS FOR THE DISPLAY, WELL, AND BOTTOM SECTION, ENSURING OPTIMAL PERFORMANCE.

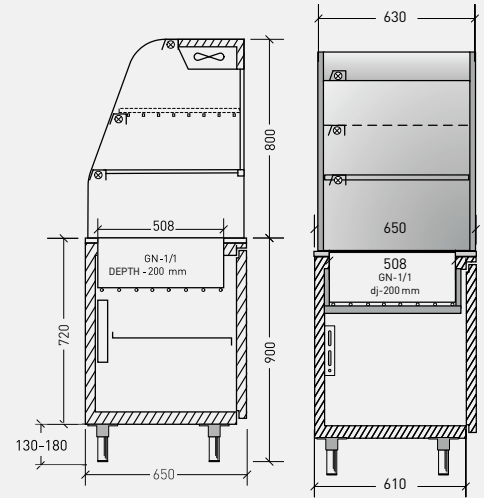

## STANDARD

REFRIGERATED DISPLAY WITH STAINLESS STEEL FRAME  
GLASS IN SIDE PANEL  
SLIDING INSULATED GLASS DOORS ON STAFF SIDE  
OPENABLE DOOR ON CUSTOMER SIDE  
FULLY STAINLESS STEEL REFRIGERATED COUNTER  
REFRIGERATED LOWER CABINET WITH REMOVABLE SHELF  
SUPPLIED WITH BUILT-IN COOLING UNIT OR FOR REMOTE COOLING  
LIGHTING ON EACH SHELF (3)  
BEVERAGE COOLING WELL WITH INDEPENDENT CONTROL  
ROUND-UP DESIGN

### COOLING WELL WITH BUILT-IN UNIT

MODEL	MMKB-08A / MMKB-08A-RAK	MMKB-12A / MMKB-12A-RAK	MMKB-16A / MMKB-16A-RAK
DIMENSION (mm)	800 x 650 x 900 / 1700	1200 x 650 x 900 / 1700	1600 x 650 x 900 / 1700
DOORS	1	2	2
POWER SUPPLY	230 V/10 A	230 V/10 A	230 V/10 A
CONNECTED POWER	600 W	700 W	700 W
REFRIGERANT	R-290	R-290	R-290

### COOLING WELL FOR WITH REMOTE COOLING UNIT

MODEL	MMKB-08C / MMKB-08C-RAK	MMKB-12C / MMKB-12C-RAK	MMKB-16C / MMKB-16C-RAK
DIMENSION (mm)	800 x 650 x 900 / 1700	1200 x 650 x 900 / 1700	1600 x 650 x 900 / 1700
DOORS	1	2	2
POWER SUPPLY	230 V/10 A	230 V/10 A	230 V/10 A
CONNECTED POWER	200 W	200 W	200 W
COOLING REQUIREMENT	600 W/-10°C	700 W/-10°C	800 W/-10°C
REFRIGERANT	R-134A/R-452A*	R-134A/R-452A*	R-134A/R-452A*

## ACCESSORIES

C02

DISPLAYS

# SELF-SERVE DISPLAYS

ALL MODELS CAN BE OBTAINED IN A STRAIGHT OR ROUND-UP DESIGN AS ON THE PREVIOUS PAGE

## REFRIGERATED SELF-SERVE DISPLAYS

MODEL	RUK-800 / RUK-800-RAK	RUK-1200 / RUK-1200-RAK	RUK-1600 / RUK-1600-RAK
TYPE	DISPLAY	DISPLAY	DISPLAY
DIMENSION (mm)	800 x 630 x 800	1200 x 630 x 800	1600 x 630 x 800
POWER SUPPLY	230 V/10 A	230 V/10 A	230 V/10 A
CONNECTED POWER	300 W	300 W	400 W
COOLING REQUIREMENT	500 W	700 W	900 W
REFRIGERANT	R-290	R-290	R-290

## STANDARD REFRIGERATED DISPLAY

- STAINLESS STEEL FRAME
- GLASS IN SIDE PANEL
- SLIDING INSULATED GLASS DOORS ON STAFF SIDE
- OPENABLE DOOR ON CUSTOMER SIDE
- UPPER SHELF IS A GRID SHELF
- LOWER SHELF MADE FROM INSULATED GLASS
- TO BE CONNECTED TO REMOTE COOLING UNIT OR A SEPARATE CHILLING UNIT
- FAN EVAPORATOR GIVES AN EVEN TEMPERATURE THROUGHOUT THE WHOLE DISPLAY
- LIGHTING ON EACH SHELF (3) / OPENING HATCHES ON THE CUSTOMER SIDE

## NEUTRAL DISPLAY

MODEL	RUT-800 / RUT-800-RAK	RUT-1200 / RUT-1200-RAK	RUT-1600 / RUT-1600-RAK
TYPE	NEUTRAL DISPLAY	NEUTRAL DISPLAY	NEUTRAL DISPLAY
DIMENSION (mm)	800 x 630 x 800	1200 x 630 x 800	1600 x 630 x 800

## STANDARD

- STAINLESS STEEL FRAME
- GLASS IN SIDE PANEL
- SNEEZE GUARD ON THE CUSTOMER SIDE
- OPEN ON THE CUSTOMER SIDE
- GLASS SHELVES
- LIGHTING ON EACH SHELF (3)

## DISPLAY ADAPTED FOR BASKETS

MODEL	RUD-1 / RUD-1-RAK	RUD-2 / RUD-2-RAK
TYPE	BASKET DISPLAY	BASKET DISPLAY
DIMENSION (mm)	570 x 630 x 800	1095 x 630 x 800
BASKETS	2	4

## STANDARD

- STAINLESS STEEL FRAME
- GLASS IN SIDE PANEL
- 2 PAIRS OF GUIDES

## ACCESSORIES

- BUILT-IN COOLING UNIT

## REFRIGERATED DISPLAY

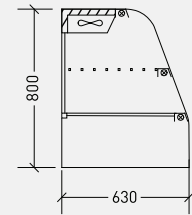
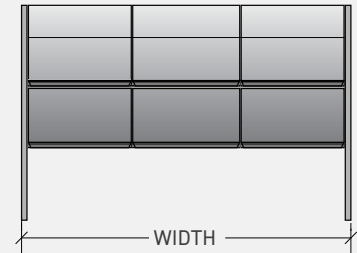

## DRY STANDS

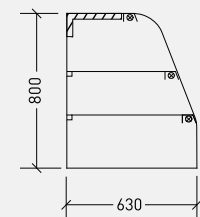
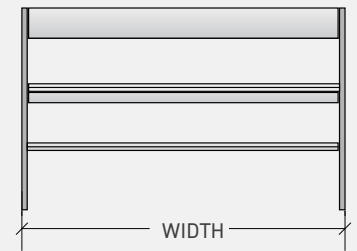

## BASKET STANDS

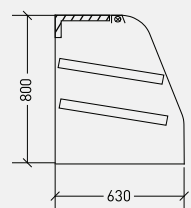
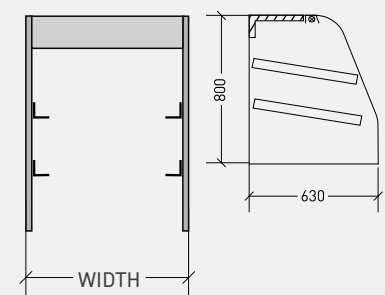



## FLÄTENS FÅNGST

Färska Rakor 199 kr/kg  
Havskräftor 199kr/kg

# DELICIOUS DELI COUNTERS

Our DELIKAT delicatessen counter series provides the perfect presentation for your finest delicacies. With a classic design and backed extensive expertise in refrigeration technology, these counters ensure optimal preservation for meat, seafood, cheese, and fresh produce. We also offer custom counter solutions tailored to meet the needs of both boutique style delicatessens and large market halls. Whatever your requirements may be, please feel free to reach out.

DELIKAT DELI COUNTERS

# DELIKAT DELI COUNTERS

## EFFECTIVE EXPOSURE

DELIKAT is our collection of deli counters designed for an elegant presentation of your finest products. With a stylish look, durable build, and energy-efficient technology, DELIKAT combines form and function. Suitable for cheese, meat, charcuterie, or seafood, each counter is tailored to specific needs. The seafood version features acid-resistant stainless steel components, a washable surface, and a drain with a strainer basket for easy cleaning.



### INTEGRATED LIGHTNING

The integrated LED lighting is energy-efficient and enhances the presentation of your delicacies with stunning clarity.



### CUTTING BOARDS

Cutting boards designed to fit the counter are available in a variety of colours, making it easier to separate different products efficiently.



### LOW-ENERGY FANS

Equipped with our energy-efficient fans.



### BUILT TO LAST

DELIKAT is crafted from stainless steel and tempered glass, ensuring superior quality and durability.



### EASY TO KEEP CLEAN

DELIKAT is designed for easy maintenance, with interior plates that lift out smoothly. This allows for quick and hassle-free cleaning of the fully welded tub.



### TILT OUT GLASS FRONT

Designed for easy cleaning and convenient front access to product labels.



### REFRIGERATED DRAWERS

For additional cold storage, the counters can be equipped with integrated drawers.



DELIKAT DELIKATESSDISKAR

DELI COUNTERS

# DELIKAT



DELIKAT 160

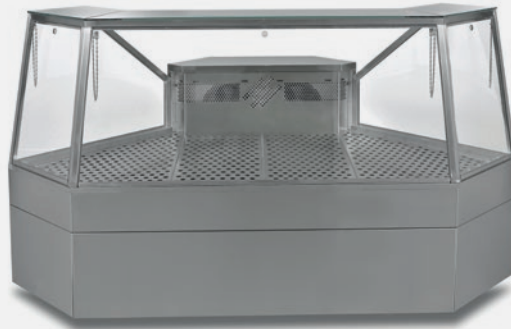

DELIKAT V90

REMOTE COOLING UNIT - STRAIGHT WITH REFRIGERATED DRAWERS

MODEL	DELIKAT-120C	DELIKAT-160C	DELIKAT-200C	DELIKAT-240C
DIMENSION (mm)	1200 x 1150 x 1220	1600 x 1150 x 1220	2000 x 1150 x 1220	2400 x 1150 x 1220
DRAWERS	2	3	4	5

CORNER STAND

MODEL	DELIKAT-V90C
DIMENSION (mm)	1700 x 1150 x 1220

BUILT-IN UNIT WITH REFRIGERATED DRAWERS

MODEL	DELIKAT-120A	DELIKAT-160A	DELIKAT-200A	DELIKAT-240A
DIMENSION (mm)	1200 x 1150 x 1220	1600 x 1150 x 1220	2000 x 1150 x 1220	2400 x 1150 x 1220

ACCESSORIES

- DIMMABLE LED LIGHT
- ACCESSORY RAIL
- SHELVES
- FOLDABLE FRONT GLASS
- STRAINER
- ACID-PROOF STAINLESS STEEL
- STATIC COOLING
- STRAIGHT FRONT GLASS
- BRINE



**MODULAR COLD ROOMS & FREEZER ROOMS**

**REFRIGERATORS & FREEZERS**

**BAKERY**

**THAWING CABINET**

**BLAST CHILLER**

**QUICK CHILLER CABINET**

**REFRIGERATED COUNTERS**

**SERVING COOLING / HEATING**

**REFRIGERATED WALL DISPLAY**

**PASTRY DISPLAY**

**DELI COUNTERS**

**WINE & BEER DISPLAY**



**HAGLUND INDUSTRI**

**KYLA I ALLA FORMER**

HAGLUND INDUSTRI AB

STORA VÄGEN 8, 523 61 GÄLLSTAD, SWEDEN / VÄXEL: +46 (0) 321-299 90

INFO@HAGLUNDINDUSTRI.SE / WWW.HAGLUNDINDUSTRI.SE